

# 750 T

4-Wheel Steer Manoeuvrability  
Compact Dimensions and Power to Spare  
One-Piece Chassis for Superior Stability

Kramer  
Tele wheel loader  
750 T



**kramer**ALLRAD®

## Technical Data Sheet

All data is valid for standard specification loader with standard bucket.



### Engine

Make	Deutz F4M 2011
Type/design	Oil-cooled, 4-cylinder, 4-stroke, in-line normally aspirated engine with direct fuel injection
Output	44 kW/60 HP @ 2400 rpm
Max. torque	195 Nm @ 1700 rpm
Displacement	3110 cm <sup>3</sup>
Emission	Tested and certified as per 97/68 EC, emissions standard level 2



### Power Transmission

Drive	Continuously variable hydrostatic axial-piston gearbox. 4-wheel drive. Brake/inching pedal.
Drive speed	0–20 kph 0–30 kph (optional)
Axles	Planetary steering axles
Total oscillation angle	22°
Differential lock	Self-locking differentials
Service brake	Hydraulic disc brake
Parking brake	Mechanical disc brake
Standard tyres	12.5 – 18



### Steering and Work Hydraulics

Mode of function	Hydrostatic all wheel steering
Steering pump	Work pump via priority valve
Steering ram	Double-acting, with automatic synchronisation in final position
Steering angle	2x 40°
Work pump	Gear pump
Flow rate	74 l/min
Pressure	210 bar
Filter	Combined suction reflux filter
Pressure limitation	Primary pressure limitation, secondary pressure in tilt ram/lift ram



### Kinematics

Design	Telescopic boom with z-kinematics
Lifting capacity	30 kN
Tear out force	49 kN
tilt in / tilt out angle	40°/40°
Tipping load (stand. bucket)	2700 kg
Tipping load (pallets)	2160 kg
Payload S=1.25 (pallets)	1730 kg / 950 kg*
Payload S=1.67 (pallets)	1290 kg / 700 kg*
Payload in transport position	
S=1.25 (pallets)	2000 kg
Scraping depth	80 mm



### Capacities

Fuel tank	60 l
Hydraulic oil tank	50 l



### Noise emissions

As per 2000/14/EC



### Electrical System

Operating voltage	12V
Battery	12V/72 Ah
Alternator	95 A
Starter	2.3 kW

# 750 T



### Operational Data

Bucket capacity from – to	0.75 – 1.2 m <sup>3</sup>
Dimensions (with standard bucket and standard tyres)	
a — Height	2580 mm
b — Length	5500 mm
c — Width	1720 mm
d — Ground clearance	300 mm
e — Wheelbase	1920 mm
f — Centre of front axle to tip of teeth	2230 mm
g — Centre of rear axle to end of vehicle	1350 mm
h — Bucket width	1750 mm
i — Pin height	3585 mm / 4660 mm*
j — Load-over height	3435 mm / 4510 mm*
k — Dump height	3000 mm / 4000 mm*
l — Dump reach	760 mm / 1230 mm*
Pallet height	3360 mm / 4440 mm*
Turning radius	
Tyres	2550 mm
Track circle	2430 mm
Bucket	4060 mm
Weight	5100 kg

(\* extended)

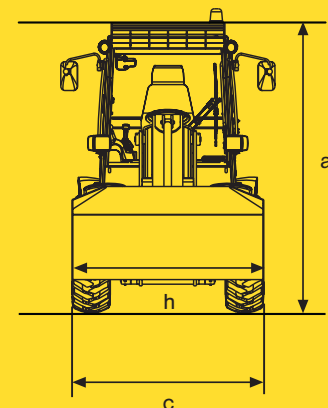
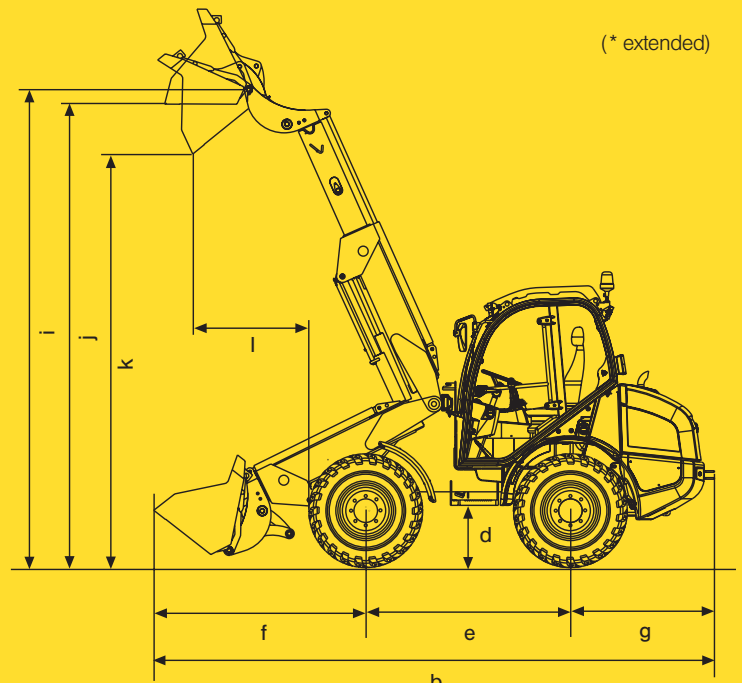

kramerALLRAD®